

pv magazine corporate

Welcoming the era of HJT

The global market for HJT

Examining the current and future outlook for the technology

Heterojunction at the height of its power

Advancements on the way to HJT 4.0

Gallery of HJT projects

A look at use cases, including world's largest HJT project in Bulgaria (650 MW)

**SPECIAL EDITION DEVELOPED
IN PARTNERSHIP WITH HUASUN**

HJT

24.16%

750.54W

Certified by TÜV SÜD in Nov. 2023

**Global Leader
in Heterojunction**

Wafer > Cell > Module

A solar future powered by HJT

In late 2023, as world leaders met at COP28 to discuss progress on meeting emission reduction targets set out in the Paris Agreement, the United States had already announced that the country had experienced a record number of billion-dollar weather disasters by September, and the EU's Copernicus Climate Change Service had reported that the summer of 2023 was the hottest on record. The call for a faster transition to renewables is loud and clear. The world simply cannot continue to wean itself off fossil fuels at the current pace.

With record production and rapidly decreasing costs, the solar industry stands ready to fill this urgent need. Solar technology has come a long way since scientists first observed the photovoltaic effect in certain materials in the mid-1800s. Cell technology, too, has evolved, leading to impressive levels of energy efficiency and power density – both of which are key to meeting the world's energy needs. Heterojunction (HJT) solar technology is one of the most recent advances to claim the spotlight in the industry, demonstrating efficiencies approaching a record 27% in the lab. Additionally, with its lower-temperature coefficient and fewer production processes compared to other cell technologies, HJT's potential in reducing the carbon footprint of solar manufacturing cannot be ignored.

Founded in 2020, Anhui Huasun Energy Co., Ltd. (Huasun) is proving its leadership in the HJT technology field. In just three years, this Anhui-based manufacturer has quickly ramped its production capabilities to 20 GW, and Chairman Jimmy Xu says the company already supplies 50% of all HJT modules shipped around the world. It has positioned itself as a proud champion of HJT technology itself, establishing a collaboration platform to tackle challenges alongside PV developers, suppliers, and research institutes around the world. The articles that follow in this special edition take an in-depth look at Huasun's activities, the recent advances in HJT technology, and its competitiveness with more mature solar technologies such as TOPCon.

In the global outlook for HJT, Huasun is fulfilling market needs in Europe, APAC, and the MENA region, where demand for renewables is surging. Installations in Bulgaria and China are demonstrating the technology's ability to improve the ROI of large-scale solar power projects, while vertical HJT modules at agrivoltaic sites in Germany are reaping numerous benefits, including 12% higher energy yields compared with south-oriented solar systems.

Photo: pv magazine/Thomas Beetz



Huasun is also working hard to bring down the cost of HJT cells, not only to be competitive with other solar technologies, but also to decrease reliance on expensive raw materials like silver and indium. At the same time, the company continues to enhance module performance, breaking module output records and receiving awards for its technology, including winning the Modules category in the annual **pv magazine** Awards for 2022. Huasun's successful R&D accomplishments are detailed in the following pages as milestones along the path to what the company is calling HJT 4.0.

The time is right for Huasun's HJT technology. The climate deal reached by the United States and China in November 2023 supports the G20 agreement to triple renewable energy capacity around the world by 2030, and the International Energy Agency's Renewables 2022 report projects that renewables will account for more than 90% of global electricity capacity expansion from 2022 to 2027. Solar will indeed play a major role in this international shift away from dirtier energy sources, and Huasun is poised to lead the path to high-performance HJT products that will bolster this transition.

Eckhart K. Gouras, Publisher, pv magazine

Imprint

Special publication

A special publication produced by pv magazine group GmbH & Co. KG in partnership with Anhui Huasun Energy Co. Ltd.

Publisher

pv magazine group GmbH & Co. KG
Kurfürstendamm 64, 10707 Berlin, Germany
Managing Director: Eckhart K. Gouras

Partner and Sponsored Content Manager

Bernadette Geyer

Editors/Contributors

Proofreader: Brian Publicover
Translators: Tim Hanes, Veritas Europa
Photo editor: Tom Baerwald
Graphics: Harald Schütt
Cover: Image provided by Huasun

Layout & typesetting

Alexx Schulz, mADVCE | Berlin

Copyright

The magazine and all of the texts and images contained therein are protected by copyright. When a manuscript is approved for publication, the right to publish, translate, reprint, electronically store in databases, print special editions, photocopies, and microcopies is transferred to the publisher. The publisher requires the author to be the holder of copyrights and commercialization rights for all submissions. Any commercial use outside the limits specified by copyright is inadmissible without the publisher's consent.



Photo: Huasun

4

Forging a path for HJT at scale

Huasun Chairman Jimmy Xu lays out the company's vision and celebrates what's been achieved so far. Huasun has grown rapidly to become the world's largest heterojunction cell and module maker, and still plans to double its current manufacturing capacity to 40 GW by 2025.

Contents

highlights ▶

- 4 **Forging a path for HJT at scale:** Huasun Chairman Jimmy Xu lays out the company's vision and celebrates what has been achieved so far.
- 6 **On the road to cheaper HJT:** Wenjing Wang, Chief Technology Officer at Huasun, discusses heterojunction technology and the company's roadmap to higher efficiency and lower production costs.

market & trends ▶

- 8 **The global market for HJT:** Demand for solar power is growing in many regions, and heterojunction technology is showcasing its potential in a broad array of projects.
- 12 **A smaller carbon footprint:** Fewer steps and streamlined processing mean Huasun technology is certified ultra-low-carbon solar.





Photo: Huasun

6

On the road to cheaper HJT

Huasun continues to innovate, pushing for higher efficiencies while reducing or eliminating rare and expensive materials from its supply. CTO Wenjing Wang lays out the company's technology roadmap.



Photo: Huasun

12

A smaller carbon footprint

With fewer production steps than its n-type rivals, Huasun has also found an HJT advantage when it comes decarbonizing its manufacturing operations.



Photo: Huasun

16

At the height of its power

Already leading the industry in efficiency terms, Huasun continues to innovate. The company is now on its third-generation cell technology, incorporating microcrystalline silicon on both sides.

technology ▶

- 14 **Advancing the promise:** Huasun has taken big technological steps in a short time to make HJT at gigawatt scale a commercial reality.
- 16 **At the height of its power:** Huasun continues to innovate with HJT tech, now on the third generation of its high-efficiency cell.
- 18 **HJT vs. TOPCon:** Advantages are emerging for heterojunction as PV enters the n-type era.
- 20 **Doing it all:** Solar's biggest and brightest are pursuing vertical integration to gain more control over supply chains and open up new innovation pathways.
- 22 **Intelligent manufacturing:** Huasun is adding the smarts as it targets 40 GW of cell and module capacity by 2025.

applications & installations ▶

- 24 **Powering Bulgaria:** Veselin Zahariev of EPC supplier Inercom discusses why HJT was an easy choice for its growing project portfolio in Bulgaria.
- 26 **Double added value through agri-HJT:** Heiko Hildebrandt, of German developer Next2Sun, sees advantage in Huasun's bifacial technology for vertically installed modules on active farmland.
- 28 **Soaring to new heights:** Strong all-black aesthetics make Huasun a perfect partner for building-integrated PV, says Marcus Bäckmann, Chief Technology Officer at Switzerland's 3S.
- 30 **Around the world in HJT:** From Xuancheng to Pazardzhik – a look at some top projects featuring Huasun technology in China and beyond.

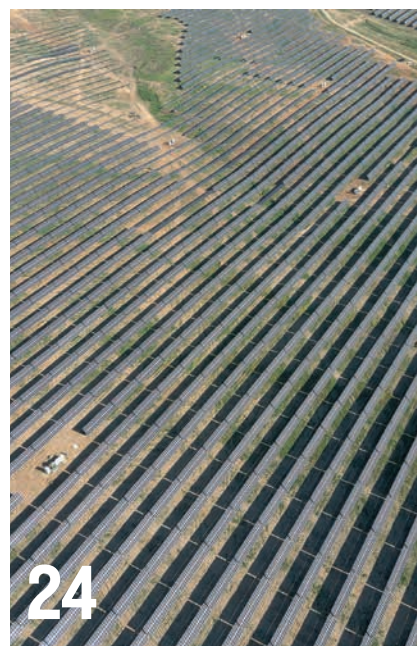

Photo: Huasun

24

Powering Bulgaria

Veselin Zahariev of EPC supplier Inercom discusses why HJT was an easy choice for its growing project portfolio in Bulgaria.

Forging a path for HJT at scale

Huasun is well on its way to achieving its goal of providing the best heterojunction (HJT) products to the world, with expanding production capabilities and advances in cell and module performance, according to Chairman Jimmy Xu. Here, he discusses the company's top achievements and its plans for the next five years.

“We serve as a large laboratory for companies in the entire HJT industry”

**Jimmy Xu,
Chairman, Huasun**

Why did you choose to focus on HJT technology when starting Huasun?

The theoretical efficiency limit for a single-junction silicon solar cell is 29.4%. The theoretical conversion efficiency for an HJT cell is 29.2%, which is the closest to 29.4% compared to any other technology. It can be said that HJT is the most perfect silicon solar technology capable of production with high efficiency at large scale and with low cost. It is not easy to commercialize HJT despite the efforts of many companies and institutes going all the way back to 1990. It is Huasun that was finally able to realize the industrialization of HJT and demonstrate to the industry that it is a high-efficiency, low-cost way to help solar projects achieve better returns. And it has the lowest carbon footprint for module production, which is better for creating a zero-carbon world. We are like the guides who try to find a path through the forest. We try to guide more people to join together to improve the technology.

Can you talk about the company's biggest achievements over the past few years?

Our greatest achievement since Huasun was founded in July 2020 is that we are the largest HJT company in the world. Over 50% of all HJT modules shipped around the world come from Huasun. We have production capacities of 20 GW, and I believe we will be the first manufacturer in the world to deliver more than 10 GW of HJT modules around the middle of 2024.

Huasun leads the HJT industry in efficiency and power output. Our modules are able to achieve approximately 4% higher energy yield per watt than any other regular module. Our cell efficiency on the production line is 26.15%, and the champion is 26.5%. The power of our champion module is 750.54 W. Third-party testing by PVEL in the United States puts our module's power generation capacity as the top ranked for HJT. Our modules also have the lowest carbon footprint – 366.12 g/W CO₂ equivalent – which was certified by TÜV Rheinland in July 2023.

We are the youngest company on BloombergNEF's list of tier-one PV module manufacturers, and we are also the youngest unicorn in the Forbes list. We completed Series C funding in the second half of 2023, and Huasun's current market value is \$2 billion, which is more than 200 times higher than when it was founded.

Huasun has become the leader in every step of HJT mass production. We developed a dedicated wafer specifically for HJT, including special wafer cutting equipment and processes, and in 2024, we plan to build a factory to use 100% fluidized bed reactor (FBR) polysilicon materials and to use the continuous Czochralski (CCZ) method for making ingots with this material. Additionally, with the launch of our Everest modules in November 2023, Huasun has become the trailblazer ushering in the HJT “R” era with modules featuring rectangular cells.

After three years of hard work, Huasun has successfully turned HJT into a high-efficiency, low-cost technology that can be manufactured in large-scale production. Our current costs are now almost comparable to TOPCon.



How does Huasun approach R&D and collaboration on HJT technology?

I've worked in the solar industry for over 20 years and in HJT for 14 years. My teacher and CTO, Wenjing Wang, has worked in HJT R&D for 25 years, and half of the top professionals in HJT R&D and mass production work for Huasun. In 2023, we spent CNY 250 million on R&D, and we'll increase that to CNY 500 million in 2024. We believe in the importance of advancing technology and invest approximately 8% of our total revenue each year into R&D, which is much higher than others in the industry.

As true believers in HJT, our mission is to make the technology successful. However, it is difficult to develop, and we need to collaborate to bring it into mass production, which is why Huasun established a collaborative innovation platform in 2023. We serve as a large laboratory for companies in the entire HJT industry.

As of the beginning of 2024, Huasun has 20 GW of capacity for HJT products, with a goal of reaching 40 GW by 2025. Where will those new facilities be located, and which markets will you focus on?

We currently have four production bases in China – in Xuancheng, Wuxi, Hefei, and Dali. We are also currently building a new facility for ingot slicing in Northwest China. Our production capacity in China is focused mainly on China and Europe, and then for the Middle East and Southeast Asia. Our domestic customers take about 50% of our production. We are still developing our newest markets in Central and South America. In addition to expanding production in China, we are considering developing some capabilities in the Middle East in 2024, which will enable us to export from there to North America.

What is your vision for the next five years?

At Huasun, our vision is to provide the best HJT solar products to the world. This means having the highest conversion efficiency for power generation, the best energy yield performance, the strongest reliability, and the lowest carbon footprint.

Huasun's goal is to maintain our position as having the largest manufacturing capacity for HJT in the world. We plan to always account for over 30% of world HJT capacity. Furthermore, we're committed to expanding our global sales and service network covering all the key countries, ensuring we can provide clients with timely and professional support. Additionally, we want to be pioneers in the mass production of HJT-perovskite tandem cells. We have been focused on industrializing the technology and plan to start a 1 GW-sized manufacturing facility within the next five years. [pv](#)

On the road to cheaper HJT

Heterojunction (HJT) solar technology has the potential to surpass the performance of its n-type rival, tunnel oxide passivated contact (TOPCon), and to beat the cost of passivated emitter and rear contact (PERC) to become the go-to technology for solar panels. Huasun has made great strides to make HJT competitive with existing options. CTO Wenjing Wang discusses the benefits and challenges of heterojunction solar technology and how his team is working to lower costs while maximizing efficiency.

What do you see as the benefits and future promise for HJT solar technology?

Surely, high efficiency is the biggest advantage for the HJT cell. It's currently about 26.15% in mass production. In the future, we project that the average efficiency of the technology in mass production will reach 26.5%.

The other advantage is that there are two aspects of the HJT solar cell that will lead to a lower cost. One is that it can use copper to replace the silver in the electrode. The other is that it can use cheaper silicon wafers.

Pure silver paste consumption on an HJT solar cell is currently around 16 mg/W. Moving to zero busbar (OBB) technology, we can replace the silver busbar with a copper ribbon. This can reduce the silver consumption to 13 mg/W. By replacing the pure silver paste with a 50% silver-copper paste, we can further decrease silver consumption to 7 mg/W. Finally, development of copper plating technology can reduce the total silver content to zero.

On the wafer side, up to now, Huasun has been using silicon wafers with a thickness of 120 micrometers. In the future, we will be able to reduce this to between 90 and 110 micrometers. Additionally, HJT is more friendly than TOPCon toward silicon wafers, so there is no need to limit oxygen density or use high-temperature processes to prevent ring-like distributed oxidation-induced stacking faults in n-type silicon ingots. HJT reduces the cost of the edge cutting wafer by around 15% compared to the normal wafer because of built-in efficiencies from the wafer-making process. Typically, when silicon cylinders are cut to form a square ingot, there is an edge left over, which is usually sent back to the furnace to create a new ingot. Huasun uses these edges to cut half-cells, thereby getting more wafer pieces from the same ingot without having to send the cut edges back to the furnace, which wastes a lot of electricity, crucible, and time.

What technological development challenges are you working to overcome?

The main challenge is the plasma-enhanced chemical vapor deposition (PECVD) process and technology used to make silicon thin film. Although we have already made advances in the development of this technology, many challenges remain.

In the lab, efficiency increases 0.5% to 1.0% when moving from our HJT 2.0 technology, which uses amorphous p-type solar technology on the back side of the panel, to the HJT 3.0. The newer generation features microcrystalline silicon thin film on both sides of the bifacial panel, with the front side being n-type and the back side being p-type. In mass production, however, the efficiency gain between generations is only 0.2%-0.3%. The reason for this is mass production equipment limitations. The deposition rate for the p-type layer is much lower than for the n-type layer, so it is necessary to find a new, faster deposition method. We can use a higher power to increase the deposition rate, but that will damage the surface of the wafer. Alternatively, we can achieve higher efficiency by means of slower process time, but that means we have to increase the size of the PECVD chamber, which will increase the equipment investment.

Another challenge is to reduce the cost of electrode. We have to reduce silver consumption and, eventually, eliminate silver altogether. Lastly, it will be challenging to coor-

dinate players along the industry value chain to overcome current limitations, this will require significant cooperation.

How is your R&D team optimizing the technology to achieve further cost savings?

There are several approaches we are taking to reduce costs. As mentioned earlier, we are moving toward OBB technology for our panels. To eliminate silver altogether, we are also developing copper plating technology for the electrode.

Regarding other materials, our team is investigating and testing indium-free transparent conductive oxide (TCO) films, and we are looking for cheaper wavelength conversion materials with a higher efficiency.

We recently developed a continuous Czochralski (CCZ) method for pulling the ingot and can use powdered silicon material to further decrease the cost of the wafer. The oxygen density of this technology is high, which means it cannot be used in TOPCon cells, but it is fine for HJT.

We can reduce the price of manufacturing equipment if we use catalytic chemical vapor deposition (Cat-CVD) and if we switch to a cheaper butyl rubber sealing process and equipment.

What is on the horizon for HJT development at Huasun?

Huasun reached 20 GW of HJT cell production at the start of 2024. We are also now self-producing three parts of our value chain: the silicon ingot and wafer, the cell, and the module.

Regarding module performance, we expect the power of a single module (210 mm size wafer and 132 half-cells) will reach 750 W in production, which is higher than both PERC and TOPCon. Additionally, we plan to use new packaging materials and technology to extend the lifetime of our HJT cells. By making advances in our R&D, we believe HJT costs will be lower than TOPCon and even lower than PERC in 2024. [pv](#)

Photo: China Photovoltaic Industry Association



“ We believe HJT costs will be lower than TOPCon and even lower than PERC in 2024 ”

**Wenjing Wang,
CTO, Huasun**

The global market

The recent COP28 meeting resulted in targets to triple global renewable energy capacity by 2030, and demand for solar power is expected to continue to grow amid a market that is transitioning toward more advanced technologies. Here we examine the outlook for heterojunction (HJT) solar solutions and the types of projects that are already showcasing their potential in major regions.

The solar industry is experiencing tremendous growth, with surpassed milestones making headlines on a regular basis. The industry as a whole surged past 1 TW of cumulative capacity by the end of 2022, and BloombergNEF (BNEF) estimates that 414 GW of global solar installations were added in 2023. Feeding optimism in the industry is the new target to triple global renewable energy capacity by 2030 – set at the recent COP28 meeting. In its Global Market Outlook for Solar Power 2023-2027, SolarPower Europe projects that 401 GW of solar capacity will be added in 2024, bringing total capacities to 2 TW worldwide in early 2025.

Despite this positive news, BNEF notes that the industry as a whole is facing high inventory, with stronger manufacturers continuing to produce modules while waiting for weaker competitors to leave the market in response to falling costs. In its Global PV Outlook, 4Q 2023, BNEF states “Although installation volumes across Europe (both in the European Union and non-EU markets) are up 35% in 2023 compared with 2022, this is less than some sources expected.” The report highlights that the 60-80 GW of inventory in the Euro-

pean supply chain could “take more than a year to work through.” Amid this landscape, solar cell manufacturers are increasingly using newer technological advances to achieve both high module power and efficiency while reducing material costs.

January 2024 insights from TrendForce analysts point to a “bleak” outlook for p-type polysilicon and a shift to the production of n-type wafers. In particular, the decline in n-type wafer prices “means that they now have a cost advantage per watt due to their ability to be made into higher-efficiency solar cells,” according to BNEF’s report, which expects p-type cells to fall below 10% of the market share by the end of 2025.

N-type solar cells exhibit many superiorities to traditional p-type cells, such as higher conversion efficiency, greater bifaciality, a lower temperature coefficient, and improved performance under low light conditions. These advantages are driving the global transition to n-type technologies.

Applications where high bifaciality is key include rooftop installations, as well as vertical agrivoltaics – both rapidly developing segments. Heterojunction (HJT) solutions on the market are



Huasun is installing modules in places as diverse as Europe, the Middle East, Africa, and the Asia-Pacific region.



Thanks to innovations in processing and materials, HJT's manufacturing costs are expected to fall below those of TOPCon and even PERC over the next few years.

Rounding out the top five is the Netherlands, which experienced a 10% increase over 2022 numbers. Despite a net-metering policy for the residential solar, the sector decreased slightly from the record levels experienced due to the energy crisis of 2022. C&I and ground-mounted solar both increased, although these sectors are now experiencing problems due to grid congestion.

Huasun's presence in Europe is bolstered by projects in Germany, Belgium, Spain, Italy, and Switzerland, as well as in the Czech Republic, Bulgaria, and Bosnia and Herzegovina. The company's HJT modules are meeting the region's demands for all market scenarios: utility scale, C&I, and residential.

Large, utility-scale projects in Europe include a 650 MW project in Bulgaria, for which Huasun is the exclusive module provider. The project, which is discussed in more detail in a separate article (see p. 24), provides more than 1 billion kWh of power per year. Because the system saves 412,000 tons of coal per year, it reduces annual CO₂ emissions by over 1 million tons.

In December 2023, Huasun signed a supply deal with a solar project investor and EPC in Serbia for projects across the Balkan Peninsula. As part of the deal, Huasun will deliver 3 GW total of its G12R Everest series rectangular modules to support ground-mounted PV projects in the region, beginning with an initial consignment of 150 MW of modules slated for Bulgaria in the first half of 2024.

Middle East and Africa

The Middle East and North Africa (MENA) region has one of the world's highest levels of solar radiation. It's no wonder that it is also experiencing remarkable growth in solar power production. All eyes were on the region as the United Arab Emirates hosted COP28 at the end of 2023.

The Middle East Solar Industry Association's Solar Outlook Report Special Edition, published in advance of COP28, emphasized strong expectations for future solar growth in MEA countries driven by the region's "audacious plan to add 209 GW of solar PV capacity." The report highlights efforts by Egypt, Saudi Arabia, and the United Arab Emirates to address water security concerns through the use of solar power for desalinization. It also emphasizes ambitious targets by individual countries, such as Saudi Arabia's goal of 40 GW of solar capacity by 2030 and Afghanistan's aim of generating 40% of its electricity through solar by 2032. The use of HJT modules in this region is a natural choice, given the technology's outstanding performance in high temperature environments.

On the African continent, chronic power outages have driven the growth in PV installations to stabilize the grid. According to the Africa Solar Industry Association, South Africa alone added nearly 3 GW of capacity in 2023, after having added approximately 1.4 GW in 2022. Data from Solcast puts Egypt at the

top of the list of North African countries for solar capacity, with 5 GW installed and another 17 GW announced or in development.

In 2023, Tunisia announced plans for 1 GW of solar through two different tenders. Huasun is already active in the country with a project in downtown Tunis demonstrating a 180 kW commercial rooftop HJT solar installation. The system, which uses Huasun's Himalaya all-black HJT modules with SMBB multi-busbar design, is expected to generate 322,600 kWh per year and to reduce annual CO₂ emissions by 321,600 kg. To improve the reliability of the HJT modules in the country's subtropical Mediterranean climate, a polyisobutylene (PIB) sealant was added to the edges of the modules to block the intrusion of water vapor and, combined with the adoption of light conversion film technology, resist the attenuation caused by ultraviolet radiation.

In addition to the Tunisian project, Huasun is also actively working with partners on projects in Iraq and Cyprus, and the company recently signed a distribution partnership agreement with Adir Energy to distribute HJT modules in Saudi Arabia. Huasun is also considering adding manufacturing capacity in the Middle East in 2024.

HJT close to home

The Asia-Pacific (APAC) region has dominated the market for solar products, and the International Energy Association's Renewables 2023 report expects more than 288 GW of PV capacity to be added in the region by 2028. According to BNEF, China alone reached 240 GW of newly installed PV modules in 2023.

Huasun has four HJT manufacturing facilities and many projects in China, with the domestic market accounting for 50% of all its production capacity. Huasun is committed to building over 40 GW production capacity by 2025 in its production bases in Xuancheng, Hefei, Wuxi, and Dali.

Projects the company is undertaking with partners in China include a 10 MW floating HJT solar installation in Shandong. The project has a power generation capacity of 12.6 MW per year and will reduce annual carbon emissions by 12,598 tons. Huasun's V-ocean module – suitable for wet environments – was developed specifically for floating and offshore projects. The manufacturer's agrivoltaic

projects in China include a 50 MW installation in Shandong and a 23 MW fishery PV system in Anhui.

In mid-2023, Huasun signed an agreement with PowerChina Huadong Engineering Corporation to supply a total of 2.02 GW of its G12-132 HJT modules to its large-scale solar power plants located in Dali, Yunnan province. The PV plants, constructed on mountains, will aid the prefecture in achieving its clean energy targets. To date, 300 MW of these projects have been built up (see photo on p. 30).

In South Asia, Huasun recently achieved registration with the Bureau of Indian Standards for its Himalaya G12 Series modules, paving the path for sales in the Indian solar market. The manufacturer is also working with the Tayyab Group of Industries (TGOIs) in Punjab, Pakistan, to build a 20 MWp solar power plant that will provide power to the group's head office.

In the Pacific, Huasun is cooperating with a Japanese utility on a 6 MW project that is currently generating over 8.7 MWh of power per year and reducing annual carbon emissions by more than 8,600 tons. Additionally, the company's HJT products exclusively power the 20+ MWp Luxshare Precision Rooftop Solar Power Project that was recently connected to the grid and commenced operation in northern Vietnam.

In Thailand, Huasun is partnered with Grow Energy on the country's first floating HJT PV project, and the company inked a separate distribution agreement with Quality Solar Distribution for 150 MW of modules. Further afield in the region, Huasun and Prosun Solar signed a memorandum of understanding (MoU) focused on promoting HJT in the Australian solar energy industry. As part of the agreement, Huasun will deliver 150 MW of its high-efficiency HJT modules, which are targeted at the residential solar market.

Further development

As demand increases around the world for solutions to battle global warming and stabilize grids in energy-starved regions, HJT technology is rapidly pulling ahead of the pack when it comes to solar power generation, due to its recognized advantages. With Huasun's advanced manufacturing capabilities and focus on tackling challenges in the further development of HJT, the company is poised to continue its domination in this growing market. [PV](#)

Currently, around

50%

of Huasun's module capacity supplies projects in China

A smaller carbon footprint

Reducing the carbon footprint of the manufacturing process for solar modules is key to making the technology truly sustainable. Huasun's streamlined heterojunction (HJT) production has led to the certification of its latest product as ultra-low-carbon solar.

Solar generates zero-emissions energy, but concerns are rising regarding the environmental and resource impact of PV module production. In today's market, the focus has shifted to evaluating the overall carbon footprint of solar modules. This shift can be attributed to the increasingly apparent effects of climate change, coupled with concerns about environmental issues and human health, as well as resource scarcity.

Examining the carbon footprint of a solar module is a pivotal aspect of this evaluation, offering a concise metric for comparing production methods. Lower carbon footprint numbers signify production processes that demand fewer of the Earth's resources, reflecting a commitment to environmental sustainability.

Silicon demand

The process of manufacturing solar cells and wafers requires significant amounts of energy in a demanding series of processes. Technological breakthroughs are critical to help shift solar manufacturing's use of resources into greener and greener territory.

A key energy demand for most types of popular PV products is the production of polysilicon, which requires high temperatures to refine to the purity necessary for the silicon wafers used

in solar. The process involves heating quartz sands in a furnace. The polysilicon is then formed into ingots, which are cut and sliced into silicon wafers for use in crystalline products. The solar industry's silicon demands are high, and solar products generally need purity in excess of 99.9999%, known as 6N purity. This is much higher purity than metallurgical silicon. The latest solar manufacturing using crystalline silicon incorporates either the mature process known as passivated emitter and rear contact (PERC), and two newer processes or technologies known as tunnel oxide passivated contact (TOPCon) or HJT solar cell technology. Each manufacturing process has its own benefits for different stakeholders, and comparing and contrasting each technology process is beyond the scope of this article.

When solar modules are evaluated by traditional metrics, elements including efficiency, cost, and reliability are typical benchmarks. However, the carbon footprint of a module is an increasing focus for many stakeholders, and already subject to regulation by many countries, including France and South Korea. In crystalline solar, which the industry's supply chain is largely focused on, only one manufacturing technique has a far cleaner production process: HJT.

Huasun sustainability roadmap

Source: Huasun

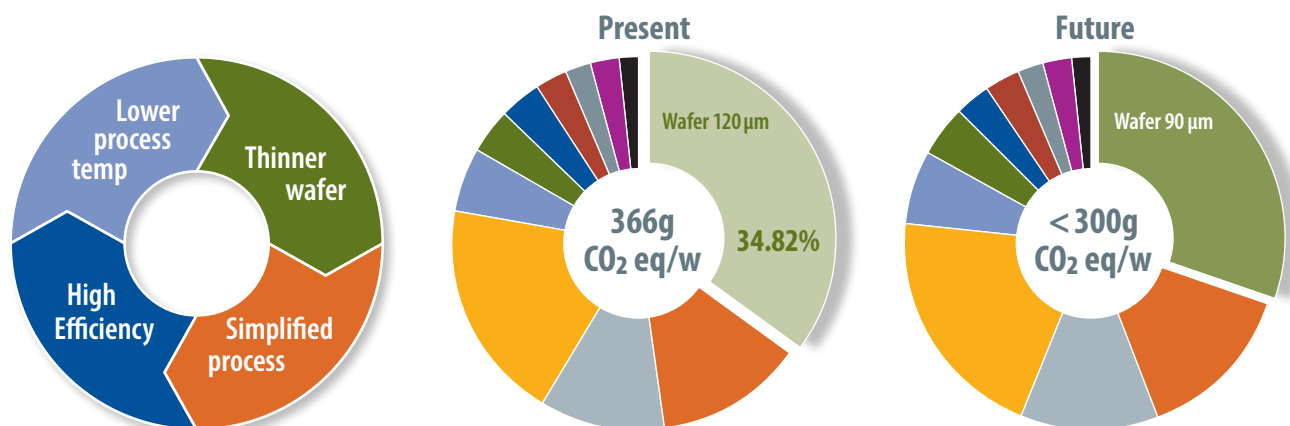

Comparing carbon

In July 2023, Huasun Energy released a carbon footprint report for its HJT solar module, the Himalaya Series G10-144, with the report certified by TÜV Rheinland. The HJT module saw a result of 366.12 g of CO₂ equivalent emissions per watt. This makes it one of the first verified solar modules falling below the 400 g/W CO₂ equivalent mark, and sees it fall into an industry category considered as ultra low-carbon solar.

The difference compared to other technologies is stark. While each manufacturer's own carbon footprint will depend on the local electricity mix used in the complete production process, broad ranges have been established by industry reports. A Fraunhofer ISE study presented at 2022 World Conference on Photovoltaic Energy Conversion in Milan published details that imply a typical glass-glass solar module made in China, where more than 85% of the world's PV manufacturing takes place, has a carbon footprint of around 750 g/W CO₂ equivalent. That means Huasun's latest module has almost half the carbon emissions.

HJT advantages

Huasun's HJT module uses silicon wafers with a thickness of 120 micrometers. That compares to a typical thickness of 150 micrometers in other crystalline silicon technologies like PERC, thereby delivering big savings on the raw, energy intensive material. In addition, Huasun CTO Wang Wenjing explained that HJT technology is, on the whole, more friendly to the silicon wafer: more of the ingot can be used. Primarily, that's because other technologies cut a solar cell after it's made, whereas HJT tech uses a half wafer before the solar cell is made, meaning a smaller segment of wafer is taken from an ingot.

"In the past, when we cut a square ingot from a cylindrical ingot, the edge part was sent back to the CZ [Czochralski] furnace to be reformed into another ingot. But with the HJT cell, we can cut the edge part to get half-Si pieces. So we can use the



By cutting wafers before they are processed into cells, Huasun can make more efficient use of silicon ingots, reducing the carbon footprint of one of PV manufacturing's most energy-intensive stages.

edge part ... to get more wafer pieces from the same ingot," said Wang. This results in both cheaper silicon wafers and more efficient use.

The energy savings from HJT go further than the wafer thickness savings and efficient use of ingots. HJT uses low-temperature manufacturing processes and a simpler production process.

Huasun brands the process a "four-step" approach, and includes clearing and texturing, bifacial chemical vapor deposition (CVD), bifacial physical vapour deposition (PVD), and a final screen printing step. At each stage, the energy requirement is lower than 200 C – drastically lower than the 800 C to 1000 C required by other solar modules. For example, the process used in TOPCon technology may take as many as 10 or more steps. In addition, lower temperatures result in fewer cracks and defects, boosting the yield of the production process and efficiency. PV

“Technological breakthroughs are critical to help shift solar manufacturing's use of resources”

Advancing the promise of HJT

In a relatively short time, Huasun Energy has taken great strides in the improvement of its heterojunction (HJT) solar tech, bringing rapid developments in the production of wafers, cells, and modules.

As different solar cell types compete for market share, HJT continues to demonstrate advantages and gain momentum. HJT is a bifacial n-type monocrystalline silicon technology. It combines the benefits of crystalline silicon and amorphous silicon thin-film technologies. HJT solar cells are already highly regarded for their excellent photoabsorption and passivation, as well as for outstanding efficiency and performance.

While p-type cells, such as passivated emitter rear cell (PERC) technology, dominated the market for many years, this type of cell can be highly susceptible to light induced degradation. The market quickly realized that n-type technologies offer better resistance to this degradation and began to develop these at scale. N-type tunnel oxide passivated contact (TOPCon) technology allowed for easy adaptation from PERC production, as well as higher efficiency and a longer lifetime. But TOPCon cells require additional manufacturing steps, and some companies have instead selected HJT. Huasun has grown rapidly to become the largest of these, having already delivered more than 5 GW of HJT products to over 40 countries around the world.

Cell level

Huasun has quickly moved from its HJT 1.0 cell – with double-sided amorphous silicon – to 2.0 with a single side of microcrystalline silicon – which can absorb a wider range of the light spectrum. With the launch of new modules in its Himalaya and Everest product line, the company is now in mass production using its HJT 3.0 technology, which adopts microcrystalline silicon on both sides.

With its intrinsic thin layer structure, Huasun's 210 mm HJT cell has an average efficiency of 26.15% in mass production and has reached a maximum of 26.5%.

While there are several companies currently working on HJT technology, Huasun's R&D team takes an aggressive approach to lowering costs. The company has pioneered the move to silver-coated copper paste as a replacement for pure silver, and it is concurrently researching further advances in heterojunction back contact, copper electroplating, and heterojunction-perovskite tandem cells.

To further decrease the cost of materials that go into producing the cells and make them more reliable – as well as harder to break – Huasun has reduced the thickness of the silicon wafer it uses to 120 microm-



Huasun has achieved a maximum cell efficiency of 26.5% in the lab, while its average efficiency in large-scale production stands at 26.15%.

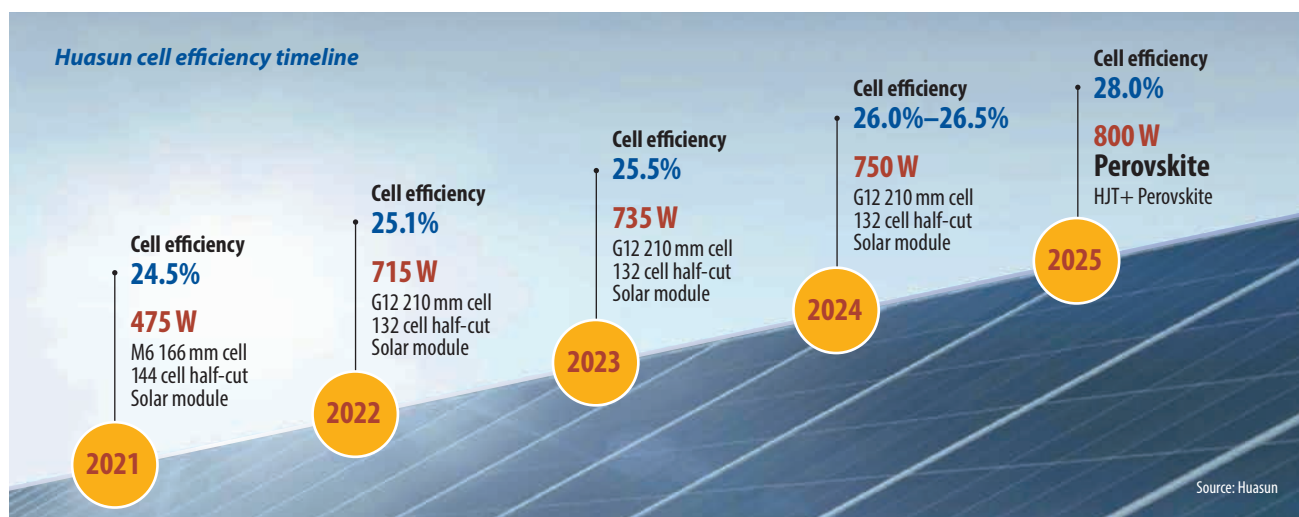

eters, and it is aiming for 90 micrometers in the future. The company has also begun to explore indium-free transparent conductive oxide (TCO) materials, as indium faces scarcity issues and is becoming more expensive.

Stronger sealing

Similar to perovskite solar technology, HJT modules have a higher sensitivity to moisture than PERC modules. Any water or moisture ingress into the units can result in degradation and corrosion, resulting in a quicker loss of power over a module's lifetime. Sealant and encapsulant options include ethylene vinyl acetate (EVA), thermoplastic polyolefin (POE), and polyvinyl butyral (PVB).

EVA has a potential to degrade and produce acetic acid over time, and POE and PVB are more expensive and difficult to handle. Therefore, Huasun's HJT 3.0 modules utilize a cheaper and more effective butyl rubber sealing technology, paired with a light conversion film encapsulation. These protect not only the PV cells within the modules, but also their connections, thereby extending the life of the module.

High stakes

In January 2023, Huasun achieved a significant milestone with its Himalaya G12-132 HJT solar module, which achieved a maximum power output of 715 W during successful testing by German certification authority TÜV SÜD. In November of the same year, the company once again broke module output records as TÜV SÜD certified the G12-132 module as reaching a maximum output of 750.54 W.

Considering the high-power output of these modules, Huasun has been working with utility-scale, multi-megawatt projects, including a 650 MW project in Pazardzhik, Bulgaria. Additionally, because of the notable bifaciality of HJT technology, the modules are well suited to agrivoltaic installations, such as the Weifang 50 MW agrivoltaic project in Shandong, China.

Huasun projects that in the future, it can reach module power outputs of 800 W or more and efficiencies of 28% through combining heterojunction and perovskite into a tandem cell. The company's attention to cost reductions at the materials and cell level has already resulted in big steps toward those goals. HJT's natural, symmetrical bifacial structure opens the door to a broad variety of applications for modules of this type, putting Huasun in a secure position, where it can continue to grow its stake in the PV marketplace.

The company has already received several awards for its technology. Huasun's Himalaya G12 series was named best module in the annual **pv magazine** Awards for 2022. In 2023, the Himalaya series module passed the Product Qualification Program of PV Evolution Labs (PVEL) and was recognized as a "Top Performer" on the Reliability Scorecard. These successes have led to Huasun being ranked as a tier-one solar module manufacturer by BloombergNEF. Huasun has also been ranking third on TaiyangNews' monthly updated Top Solar Modules list since September 2023, until the time of this publication and is listed as the top manufacturer using HJT technology. **PV**

Huasun has already delivered

5 GW

of HJT products to projects around the world

Heterojunction at the

As it strives to increase performance while simultaneously reducing costs, Huasun has quickly moved from its first-generation heterojunction (HJT) cell to its current third-generation cell, and the innovation continues.

Increasing the power conversion efficiency of a solar module from 23.30% to 24.16% in the eyes of someone that is not familiar with energy matters, or the photovoltaic industry, may seem like negligible progress.

For those who work in this sector, however, these results are clearly a huge leap toward better-performing photovoltaic projects and a lower levelized cost of energy (LCOE), provided that module manufacturers can then scale up the technology in mass production without an unmanageable increase in production costs.

Huasun was able to achieve this result between March and November 2023, at least from an efficiency perspective, with a HJT solar panel that saw its power output increase from 723.97 W to up 750.54 W, with certification body TÜV SÜD confirming the results.

The Himalaya G12-132 module is made up of bifacial micro-crystalline G12 HJT cells with 20 busbars, produced independently at the Huasun Xuancheng Phase IV HJT Cell Project.

Cost vs. efficiency

The company acknowledges that there is a tradeoff between high efficiency and lower cost yet is confident that major hurdles may soon be overcome.

“We already arrived [at] a level of silver (Ag) paste consumption around 16 mg/W,” according to the company’s CTO, Wenjing Wang. “If we want to further increase the efficiency, we will have to use the slower plasma enhanced chemical vapor deposi-

tion (PECVD) process and more Ag paste. We may arrive at higher average efficiency in mass production, such as 26.5%, and the module power may even arrive at 750 W. But that requires more process equipment and more Ag paste consumption.”

Furthermore, the company is aiming to reduce electrode costs and has utilized standardized manufacturing solutions such as copper (Cu) plating, Ag/Cu pastes, wavelength conversion encapsulant film, butyl rubber sealing technology, wafer cutting technology, and novel chain type wafer gettering.

New cell architecture

The HJT solar cell technology developed by Huasun doesn’t utilize traditional monocrystalline wafers, but n-type wafers based on microcrystalline silicon. This material, which is being widely utilized among thin-film solar cell makers, has the advantage of a high carrier mobility, due to the presence of crystalline silicon (Si) grains in the microcrystalline material, and low bandgap energy.

Furthermore, Huasun has developed a method in wafer manufacturing to make more efficient use of the available ingot material. “We can use the edge part of an ingot, when we cut the cylinder into a square ingot,” Wang said. “There is an edge left that we can use to get more wafer pieces from the same ingot. The edge part is commonly sent back to the Czochralski (CZ) furnace to rebuild new ingots, but we can also cut the edge part to cut pieces to be used directly in our HJT cell.”

Huasun HJT cell diagram

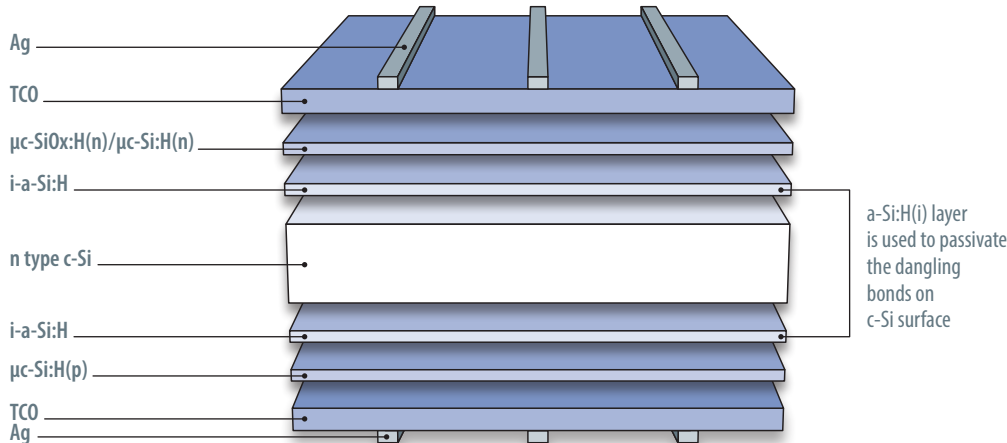

Source: Huasun

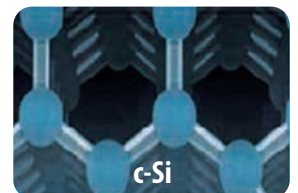

height of its power



In its R&D, Huasun is working to eliminate some of the more costly and scarce materials from production, so it can continue to improve the efficiency and lifetime of its products.

“We call this cell generation HJT 3.0, as it differs from our previous products for using microcrystalline silicon only,” Wang said, referring to the newest product developed by the company. “For our first generation, we used amorphous silicon (a-Si) thin film and for the second we used both amorphous and microcrystalline.”

Compared to the second-generation device, the third-generation cell has demonstrated up to 1.0% higher efficiency in the lab, and up to 0.3% higher efficiency in commercial production, according to the company.

The cell also relies on carrier-selective passivating contacts (CSPCs) made of micro-crystalline silicon monoxide. These contacts lead to a spatial decoupling of carrier generation and carrier separation in the cell and offer remarkable passivation, improved carrier selectivity, and low contact resistivity.

The cell also features the so-called super multi busbar (SMBB) technology, which is an evolution of the multi busbar (MBB) standard and consists of using a dense network of busbars (usually more than 10), which reduce resistance and improve shading tolerance.

HJT 4.0

As a company that is always innovating and improving upon its technology, Huasun has created a roadmap for its cells. Moving to HJT 4.0, the company will optimize the transparent conductive oxides (TCO) layer and reduce the thickness of the silicon wafer down to 90 micrometers. To further reduce costs, the company aims to decrease the amount of silver needed in each cell, with the ultimate goal of completely eliminating silver with the move to copper plating.

Wang said that the evolution to HJT 4.0 will also involve a transition to zero busbar (0BB) technology, paving the way to efficiencies of 26.0-26.5% in mass production. Beyond Huasun’s fourth-generation plans, the company is already exploring the development of HJT+perovskite tandem cells that could reach 28% cell efficiency, with 800 W of power capacity.

The company plans to verify the tandem technology on a 210 mm solar cell and to verify mass production equipment for the perovskite cell, targeting mass production of tandem products by 2025. [PV](#)

HJT vs. TOPCon on the way to lower LCOE

As heterojunction (HJT) solar technology breaks record after record, it is quickly becoming apparent that it holds exceptional promise for reducing the levelized cost of energy (LCOE) compared with other cell technologies.

Looking back in time, cost reduction and efficiency enhancement were always the core influencers in the development of the PV industry. Before 2015, back surface field (BSF) cells dominated and accounted for 90% of the total market, while passivated emitter and rear cell

(PERC) reached commercialization with a higher efficiency that broke the 20% ceiling of BSF. In 2018, only a few years into its spread, the market share for PERC cell jumped to 33%, and increased to 87% in 2020, replacing BSF. Since then, new solar cell technologies have been maturing and seeking the opportunity to beat PERC with higher efficiency, better performance, and a lower LCOE.

HJT and tunnel oxide passivated contact (TOPCon) are the two main technol-



HJT technology allows for the use of much thinner cells, significantly reducing polysilicon consumption.

ogies currently vying for market share, and Huasun believes that HJT has several key advantages over its n-type rival.

Cell characteristics

The HJT cell has much better resistance to light degradation. In its 30 years of service time, the efficiency degradation of HJT cells is less than 12%, compared with a typical value of 13% for TOPCon technology. Meanwhile, an HJT module's bifaciality can reach up to 97% – more than 10 percentage points higher than TOPCon's 85%. On the surface structure, both sides of the HJT cell have crystalline silicon and/or amorphous silicon structure, which helps it to realize double-sided passivation. HJT has a better adaptability, too, with a lower temperature coefficient of -0.24% per degree Celsius, lower than the -0.3% per degree Celsius for TOPCon. All these characteristics help HJT to generate more power than TOPCon.

Investment costs

TOPCon cells can be produced by upgrading existing PERC manufacturing lines. However, PERC production requires at least nine processes, while TOPCon requires 12. In comparison, HJT needs just four processes. More processes necessitate more equipment, larger land and factory occupation, as well as more power and supporting resources. More importantly, using more processes significantly reduces the yields of the final solar cell products. Moreover, to solve all the technical difficulties in all the processes – including final yields – increases R&D costs.

The HJT production line has relatively simple processes, smaller factories occupying less land, fewer power and support requirements, and a higher concentration on R&D that results in bigger yields. Even the equipment cost, with continued improvements and scaling, is becoming cheaper. The line investment cost required for HJT technology is very close to TOPCon, if one is starting from scratch to build capacity.

Production costs

The cost of producing solar cells can be roughly divided into three areas: Investment in the production line, polysilicon costs, and non-polysilicon cost (primarily silver). HJT manufacturing uses a low-temperature process, which makes it possible to use thin or even super-thin wafers, greatly reducing polysilicon cost.

In the lab, researchers are working with wafers just 90 micrometers thick. Some HJT producers have successfully launched HJT cells mass produced with 110 micrometer wafers. Due to high temperatures used in the process of boron diffusion, and subsequent shifts in temperature, it would be difficult for TOPCon cells to be made on such thin wafers. Current TOPCon cell technology uses wafers around 130-135 micrometers thick. Additionally, because of the high-temperature boron diffusion process, it is almost impossible for TOPCon to reduce its silver consumption, which is currently around 13 mg/W. But HJT technology uses a low-temperature silver paste with high abatement potential. Many HJT players – including Huasun – are replacing silver with silver-coated copper, which can reduce the total cost.

Calculations using data from a commercial installation in China show the advantages of HJT modules compared with TOPCon (based on an M10/182 mm, 72-cell PV module). On the same land area, an HJT system can provide 4% more power than TOPCon. Because fewer modules are used, HJT technology can reduce racking cost by 7.43%, cable cost by 6%, and electricians by 2.5%. Compared with TOPCon, the general balance of system (BOS) for HJT will be 3.2% lower and the LCOE will be 1.73% lower. Due to the lower BOS and LCOE, the internal rate of return (IRR) for an HJT installation will be 4% to 8% higher than that for a TOPCon project of the same scale.

Comparable calculations for several other kinds of solar projects – such as agricultural PV and offshore water surface PV – have reached similar conclusions.

With the steady growth of HJT products and the constant improvement of production processes, the mass production efficiency of these cells continues to increase. According to Huasun, the efficiency of its Himalaya-G12 series cells in mass production reached 25.5% at the end of 2023 and will reach 26% to 26.5% in 2024. In 2025, with the introduction of HJT-perovskite tandem technology, cell efficiency is expected to hit 28%. At the same time, Huasun projects that an HJT module based on a 210 mm wafer and advanced cell technology will easily exceed 800 W of capacity. At that point, TOPCon will fall out of fashion and become obsolete due to its inability to incorporate next-generation cell technology. 

Just

four

process stages are needed to turn silicon wafers into HJT cells

Doing it all

Vertical integration in solar offers opportunity and risk. But the biggest and best in the industry, Huasun among them, are moving toward tighter control over supply chains, opening new doors for tech innovation.

Solar manufacturing has proven to be a game of scale, matching production tools with efficiency and effectiveness. Manufacturers typically battle high depreciation rates on tools, and changes in production setups can therefore be expensive. Adding vertical integration for manufacturing creates further complexity. However, the vertical integration of the entire chain remains the cornerstone for achieving the primary goals of technology upgrading, cost reduction, and low carbon emissions.

Huasun's move to vertical integration involves maintaining expertise across a large portion of its supply chain and represents a robust commitment to research, development, and quality control.

It offers a fascinating case study of how it navigates the challenges and opportunities of vertical integration in this field. The company was the first major player to move into heterojunction (HJT) solar production and was the first in establishing a gigawatt capacity monocrystalline HJT production line. It now stands as the world's largest vertically integrated heterojunction products and solutions provider.

Such large-scale facilities can significantly contribute to efficiency and production capabilities, but at the same time, the vertically integrated nature of the process requires an ongoing commitment to research, development, and quality control to make it all work.

Tech integration

Huasun's vertical integration spans the entire HJT chain, from rod pulling and ingot slicing, to its production of solar wafers, cells, and modules, and has a strong focus on R&D in technology and innovation. Despite being a relatively young company, Huasun has taken on the challenge and complexity of large-scale production in HJT, which is still in its

early years compared to other solar manufacturing, including PERC and TOP-Con. Its choice of vertical integration in HJT therefore allows for tight control over the process but adds further degrees of difficulty.

Huasun Chairman Jimmy Xu says that cell production, for example, demonstrates the intense technological detail necessary for HJT. "To produce ultra-thin solar cells, changes are necessary in the slicing equipment and cutting methods," says Xu. "After slicing into thin wafers, the equipment and process for cell production need to be adjusted accordingly, and the subsequent module also needs to adapt. There is a very high level of correlation between the front and back ends, so it is crucial to ensure close collaboration upstream and downstream."

To swiftly address the gap in the ingot pulling process for HJT, Huasun has pioneered a Continuous Czochralski (CCZ) method and can utilize granular silicon material to significantly lower wafer production costs. In 2024, a new factory with a total capacity of 20 GW is planned in Northwest China to implement the CCZ method for ingot production using granular silicon. This proprietary technology and process developed exclusively by Huasun integrates the entire industry chain, promising enhanced performance in terms of improved production efficiency, reduced costs, enhanced cell performance, and a diminished carbon footprint. Undoubtedly, this represents an unprecedented industry application of the technology in mass production, marking a significant milestone in the HJT field.

Through managing these elements and its technology, Huasun has results. It achieved a huge increase in solar cell efficiency, with an average cell production efficiency of 26%+. German testing and certification group TÜV SÜD has confirmed efficiency results for production modules, and the Institute for Solar Energy Research in Hamelin, Germany, has confirmed new cell benchmarks, including 25.69% efficiency from a first batch of 210 mm cells from the Huasun Dali 2.5 GW Phase I HJT Cell Project.

Huasun's expansion – the story so far

- Founded in 2020, Huasun grew to become the world's largest HJT producer in mid-2022.
- Its current manufacturing facility capacity is 6 GW for wafers, 20 GW for cells, and 20 GW for modules.
- By 2025, the target is for production of 40 GW for the entire chain of HJT products.

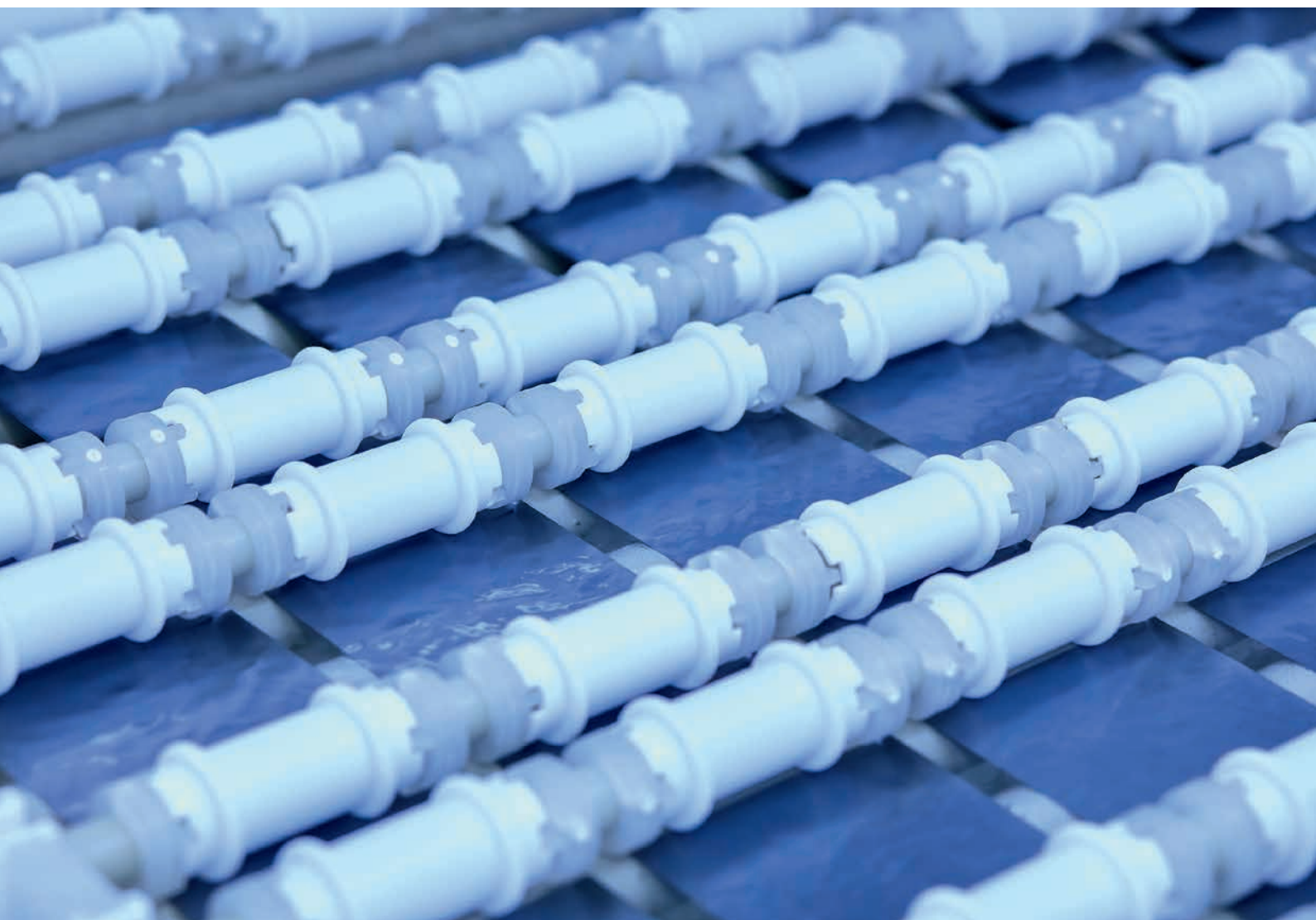

Huasun is a vertically integrated company, producing wafers, cells and modules.

Huasun also said it expects to maintain an average efficiency of 26.15% in mass production and says it has reached 26.5% efficiency in some champion cells.

Lighting the way

As part of its vertical integration successes, Huasun is also in the process of establishing a lighthouse factory for its HJT technology: a state-of-the-art manufacturing facility that serves as a model for other factories to follow, equipped with the latest manufacturing technologies and processes.

Dedicating attention to comprehensive quality management, Huasun has implemented full-process oversight of incoming materials, encompassing silicon wafers, solar cells, and modules to ensure superior performance. The company holds ISO 9001 quality management system certification, and its HJT products have successfully undergone professional

industry testing, earning a series of certifications attesting to product quality and safety.

Huasun is working in wide partnerships to innovate across the entire supply chain. The company explained it has been working with more than 130 stakeholders in the industry in a global collaborative innovation platform for the industrialization of HJT technology. Organizations include those already in the PV industry chain, along with universities, third-party testing organizations, research institutions, and more.

Through collaboration with all supply chain partners to construct a synergistic and complementary product value chain system, Huasun seeks to consistently enhance business processes. The goal is to establish an alliance for quality and process improvement, ultimately achieving the continuous growth and sustainable development of heterojunction. [PV](#)

Intelligent manufacturing of HJT solar modules

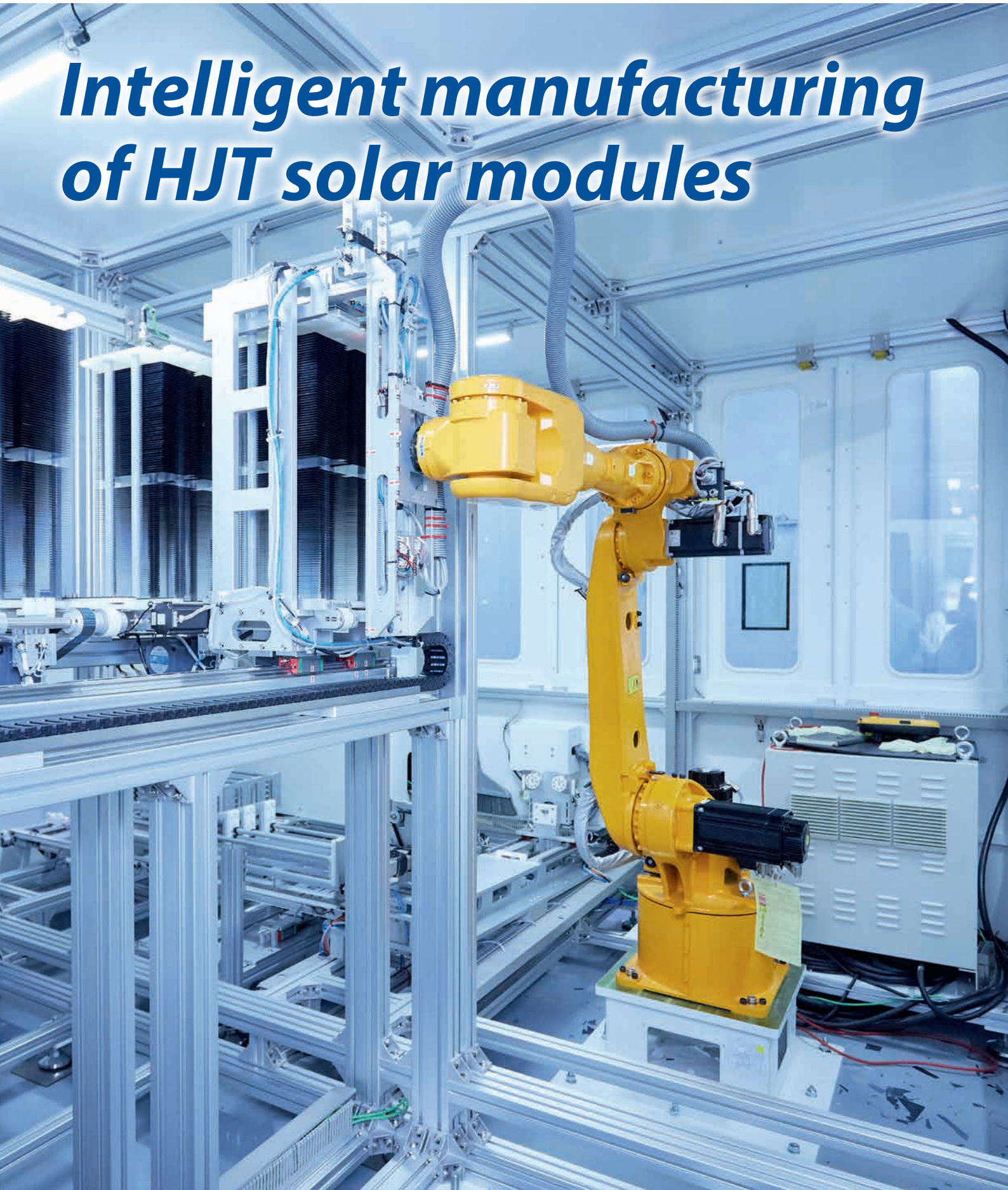

High-density fine busbar printing technology, using a low-temperature silver paste, is a key stage in HJT cell production.

Huasun uses technological innovation throughout the manufacturing process of ultra-high efficiency n-type silicon-based heterojunction (HJT) solar technology.

HJT solar cells combine the advantages of crystalline silicon and thin film technologies with excellent light absorption and passivation effects. They are superior to other technologies in efficiency, performance, carbon footprint, and more. In contrast to other types of solar cells that are manufactured using ten or more steps, Huasun has streamlined its process to just four steps for its HJT cells: cleaning and texturing, double-sided CVD, double-sided PVD, and silkscreen printing. This exceptionally streamlined process aims to maximize cost reduction and efficiency enhancement in mass production.

Each HJT module, before reaching the end users, undergoes a journey marked by smart production and rigorous control. This includes processes such as soldering, laying, stitch welding, lamination, framing, and solidification, along with multiple rounds of inspection and testing.

Based on smart and lean manufacturing systems, Huasun enhances business digitization, production automation, and process standardization. Through business digitization, a digital system becomes the control center for managing the company's manufacturing performance. Production automation integrates digital management tools to set up closed loop manufacturing. And by standardizing processes, the company optimizes production, designing and building a benchmark base for the smart manufacturing of state-of-art HJT cells and modules.

Digital twins

Revolutionizing the manufacturing process through digital twins, Huasun has established a comprehensive intelligent manufacturing management platform seamlessly integrated with operational and warehouse management systems. This accomplishment facilitates highly efficient management across the entire chain, encompassing raw materials, equipment, production processes, quality control, sales, transportation, and customer service.

Huasun uses state-of-the-art production lines controlled by centralized software, enabling all production equipment to detect and report any faults right down to the single chip during the production run. In addition to producing high-quality, fault-free cells, the production equipment is able to output an estimated 14,400 pieces per hour.

In its GW-level single-side microcrystalline technology, Huasun has also introduced silver-coated copper pastes in mass production, which significantly reduces cost while maintaining HJT cell efficiency and reliability. However, again, this is an innovation to the industry and requires close control. This includes advanced temperature and humidity control systems in the facility and a manufacturing execution system (MES) for precise big data management, to track and trace the quality of individual cells and modules during mass production.

Quality control

It is crucial for users to get a clear and full picture of the products they've purchased. Typically, those produced with shorter lead times, lower costs, higher quality, smarter tracing, better delivery, and easier customization are the optimal choices for them.

Embracing the business philosophy of prioritizing quality, Huasun has established a sophisticated intelligent manufacturing system by acquiring the most advanced and well-matched equipment and software. This includes supplier quality management, advanced process quality monitoring, global customer services, product performance guarantees, and rigorous shipment control. The system succinctly traces and analyzes all processing data, enhancing production efficiency and flexibility to meet various customer requirements.

With the swift progress of artificial intelligence (AI), Huasun has taken the lead in the industry by pioneering the application of AI in smart manufacturing. The company has successfully integrated AI into finished product inspections and expanded its utilization to quality control processes, such as string welding. 

Huasun's manufacturing tools produce up to

14,400
cells per hour

Powering Bulgaria with HJT

Veselin Zahariev, the chief financial officer of engineering, procurement, and construction specialist Inercom, talks about the state of large-scale solar in Bulgaria and why the company ultimately selected heterojunction (HJT) modules from Huasun for multiple solar parks in the country.

What types of solar projects is Inercom currently working on in Bulgaria?

Over the last two years, Inercom has built 400 MW of new solar parks in Bulgaria, using the bifacial heterojunction solar panels from Anhui Huasun Energy Co., Ltd (Huasun). That project, which began in 2021, is the Apriltsi Village solar park in South Bulgaria. It is expected to be completed by Q1 2024. Once it is in operation, it will be the world's largest HJT solar plant.

Inercom is currently developing another 700 MW of new projects, which will be launched between 2024 and 2026, all of which will use Huasun's HJT technology.

Can you tell us about the market for large-scale solar projects in Bulgaria?

The electricity market in Bulgaria is in a market union with the European electricity markets, it is very dynamic and flexible, offering medium and long-term products for producers from renewable sources. Solar energy in Bulgaria is not subsidized. Energy facilities built after 2019 are managed by local and international investors on a market basis. Now, the installed photovoltaic capacities in Bulgaria are a little more than 2.5 GW, and the expectations are that in the next four years they will grow to 5 GW.

Growth in the solar industry is driven by green transition policies of the European Union and the expected decommissioning of coal-fired power plants, which underpin Bulgaria's current electricity generation capacity. Bulgaria has launched a project to build 1 GW of new nuclear power capacity, which it expects to be operational in 2038.



Inercom has built 400 MW of solar in Bulgaria, and expects to complete another 700 MW by 2026.

How is the Bulgarian government supporting utility-scale solar projects?

The Bulgarian government follows the common European policy of reducing the carbon footprint of the energy sector and significantly increasing the share of renewable energy in the country's gross consumption. Eased administrative procedures and deadlines for joining solar centers were adopted, with the aim of achieving maximum utilization of the country's climate potential for solar, which would also modernize the entire energy sector.

The "polluter pays" principle has been fully adopted, which puts significant pressure on the economic viability of the country's coal-fired plants, which must be charged an average of €89.00 (\$96.33) per ton of greenhouse gases, making the price of electricity produced uncompetitive. Naturally, this policy sits at the center of the incentives for the construction of renewable energy plants. The package of subsidies is now being extended to business users and households in the form of direct subsidies under the Recovery and Resilience Plan, including by providing incentives for the construction of energy storage infrastructure. These incentives, along with access to trade in guarantees of origin, provide additional income. In addition, the state-owned electricity system operator (ESO) is investing over €500 million in its energy network in 2023 and 2024 to accommodate new solar projects.

Last but not least, there is an ongoing discussion at government level about the future of the coal-fired regions. A strategy is being discussed to replace the large state-owned coal-fired power plants in the East Maritsa Basin – which are expected to be decommissioned in the next few years – with scaled-down solar and hybrid projects that will use the existing energy infrastructure and the good physical connection with the networks of Bulgaria's southern neighboring countries.

What are the benefits of HJT solar technology for utility-scale projects?

Although mainstream PERC technology is clearly cheaper and still preferred by many investors and EPC contractors, Inercom believes that HJT technology is the future. There are two primary reasons why HJT is better. First, the better quality of HJT technology provides for a higher energy yield.

Second, though HJT technology is still young and we have not yet experienced a full life cycle of a project (25-plus years), it is expected that HJT panels will have a significantly lower degradation and fewer technological failures than other panel types. This not only increases the life of a project, but also allows for better operation and maintenance (O&M), which will become a crucial factor after the huge wave of global investments have passed and investors focus on improving O&M in an environment of rapidly changing technology.

What is the most recent agreement Inercom has signed with Huasun and how does this build on the cooperation that the two companies began in 2021?

Inercom started its cooperation with Huasun in 2021 with the supply of 86 MW HJT modules. Since then, Huasun has been our trusted partner. We have signed numerous contracts and agreements with them for hundreds of MW of HJT products and built a sustainable and meaningful business relationship.

In April 2023, Inercom and Huasun signed a memorandum of understanding for the period 2023 to 2025 and a new framework agreement to provide at least 1.5 GW Himalaya series ultra-high-efficient HJT modules by the end of 2025 for Inercom's large-scale utility projects in Bulgaria. This is a great commitment that emphasizes our company's satisfaction with Huasun's high quality, outstanding technical performance, and reliable delivery capabilities.

In 2024, Inercom will continue to place orders for Huasun's HJT technology under this framework agreement. We already plan to extend this successful partnership with the signing of another contract for 350 MW of new capacity.

What types of projects do you have coming up in 2024 and where will they be?

The new projects for 2024 will be located in Bulgaria and will be HJT solar projects. Traditionally, the team is focused on and develops its expertise in large-scale projects. Agrivoltaics is a challenge that we are still researching and developing, so it can be implemented according to our principles and strategies to comply with all environmental norms and respect for agricultural lands. 



“ We already plan to extend this successful partnership with the signing of another contract for 350 MW of new capacity ”

**Veselin Zahariev,
Inercom**

Double added value

Vertical PV installations with bifacial heterojunction (HJT) modules bring many benefits, particularly to agricultural land. Heiko Hildebrandt, Managing Director of Next2Sun, explains how his company's racking systems and Huasun's modules are changing the way that Germans think about land-based PV.



“When we purchase modules, we like to get a little bit deeper into the detail”

**Heiko Hildebrandt,
Next2Sun**

Can you talk a little about Next2Sun and how the company has evolved?

I founded Next2Sun in 2015, originally to sell racking systems for photovoltaics. At that time, most installations used south-facing PV systems, but we were starting to think about an optimization of the east-west oriented systems to get the highest yield out of the solar panels. This brought us to consider using bifacial modules, installed vertically, to have the sun shine on both sides.

After conducting simulations and determining that it could work, we designed a vertical racking system and installed a small, 25 kW plant with three rows to try it out. After the first week, we were surprised that the yield was about 10% higher than a common south-oriented system. We then patented the racking system and kept working to improve it. Originally, we just wanted to produce and sell this racking system we invented. But in those days, it took us a lot of time to explain to customers why it was a good idea to install PV modules vertically. We had a hard time finding anyone who wanted to invest in a PV plant with an installation system that nobody had ever used. They wanted to see real data. So we decided to install the first plants on our own. In 2018, we installed our first bigger plant, which was about 2 MW.

After a period of purchasing PV modules just for our own installations, we started to also sell PV modules to our customers, so we now manage projects from start to finish. It's got easier to explain what we're doing now that vertical systems are more common.

What are the benefits of a vertical system using HJT technology?

After installing our own plants, we realized that the energy we produced with our vertical system in the morning and the evening hours was worth more money on the energy market, because most PV plants are south-oriented and produce power during the middle of the day. In those hours, you don't get much money at all for your system. Another benefit is that the vertical systems can be located on agricultural sites. In Germany, it's typically difficult to find available land for PV plants, because you can't use a field for agricultural purposes with a south-oriented system. We were the first to do agrivoltaics. Over the past few years, it has become more common and everybody's talking about it, but we've been doing it for nearly 10 years.

We changed our system to HJT in recent years because of the technology's high bifaciality. And the prices for HJT are currently not much higher than for TOPCon modules. We researched suppliers and found that Huasun's HJT modules had 20% to 25% higher bifaciality than PERC modules, which means we earn about 12% more energy and more money with the system.

Finally, we've seen that crops benefit from the vertical PV system, because the water availability for the plants is higher. The reason is that in the morning, the water doesn't evaporate as fast. So, crops are growing faster or growing with a higher yield.

Why did Next2Sun start collaborating with Huasun, and what types of projects are you working on together?

Frames reduce module yield by about 10%, so we only use frameless, glass-glass modules in our installations, in order to get the highest yield with our system. We checked the market for suppliers that could produce frameless modules, also in small quantities of around 5 MW for one system. Huasun met our needs.

When we purchase modules, we like to get a little bit deeper into the detail. We found it interesting to talk with Huasun about the technical aspects and specifications we could change to get more power out of the modules and increase bifaciality. It's been a plea-

through agri-HJT



Installing modules vertically in an east-west orientation can spread energy generation more effectively throughout the day, while also enabling PV installations on active farmland.

sure collaborating with Huasun. It's a very good combination of our racking system and their focus on HJT modules.

Our customers request inexpensive systems, so pricing is just as important as quality. It's good that Huasun is a supplier for both cells and modules, because they know the high quality of the cells they are using in their modules. Huasun is also able to sell the modules cheaper, because they have the production for both in house. They don't pay a high margin to a different cell supplier.

Most of our projects are at agriculture sites, so we purchased 35 MW of Huasun HJT Modules this year to equip these plants. Within our agri-PV plants, we are able to adjust the pitches in response to the needs of different crops. We're also able to install up to three modules on top of each other to increase the power density of our plants, with the capability to realize efficient agriculture between the solar modules.

How do you see the market for agrivoltaics developing?

I see the agrivoltaics market developing very positively for Next2Sun. It's hard to find available land for traditional south-oriented PV systems because the agriculture people don't want them on their sites. It's more attractive if you're able to install the PV plant alongside the crops, which can continue to grow and perhaps even have higher yields. There's also the fact that we can produce energy in the morning and evening. This helps the energy transition to be realized efficiently, as the ability to earn more money from the power generated in those times helps shorten the payback period for PV installations. That's why we expect that our system will achieve significant growth. [PV](#)

Soaring to new heights in Switzerland

Climate and terrain make heterojunction (HJT) an important technology for large solar projects in Switzerland, according to Marcus Bäckmann, Chief Technology Officer at 3S Swiss Solar Solutions.

Can you talk a little about the market and incentives for residential and small commercial solar in Switzerland?

In 2022, the market volume in Switzerland surpassed 1 GW for the first time. And that was supported by subsidies. However, Switzerland has a very complex political system with 26 cantons, and you see that in the subsidies.

At the federal level, for installed PV systems, you get a fixed price or a fixed subsidy per installed kilowatt, which is at least CHF 300 (\$340) nowadays. This can even be higher, depending on whether you put it on a building's facade, or if you put it at an altitude higher than 1,500 meters. Local subsidies and additional bonuses offered by the cit-



Huasun's range of aesthetic all-black modules made it an attractive partner to 3S, which has long been active in the BIPV space.

ies and by the cantons are also available. There is not a unified, country-wide feed-in tariff in Switzerland. Instead, we have a number of different electrical companies, each with their own individual arrangements, which depend on where you live. In some areas, there's a market price standard, which, depending on the time of the year and the net load, gives customers quite good revenue. In other areas, it's limited. There's a cap. But there, you get a payment for each kilowatt-hour. Due to the market price, a lot of people opt for self-consumption, because it pays off. There's a significant focus on doing the financing by themselves, since the current payback period is under six years in Switzerland. They consume the power themselves, and they consume their own electricity. They don't buy from the grid.

How is 3S working with Huasun in Switzerland?

3S is focused on building-integrated PV (BIPV) – we produce our own modules for solar roofs, facades, balconies and overhead solutions – but obviously, you cannot cover every project with BIPV. During the pandemic and related disruption of supply chains, our partners in Switzerland approached us and asked for support: “You produce high-quality modules and you have a lot of expertise. Can you support us in selecting a high-quality module for on-roof situations?”

We conducted research and we found Huasun. We evaluated the company and concluded that they would be a very good partner because of their quality and because they focus on the heterojunction cell. So, now we have a partnership for distributing Huasun's modules in Switzerland.

What attracted 3S to Huasun?

There were two things that attracted us. First, we're not just interested in any PV, we're also focusing on nice-looking PV for the on-roof modules. And Huasun's portfolio has a lot of all-black modules, with black frames, black backsheets, black print.

The other thing is the technology. The Huasun modules have a superiority in module efficiency, and this is why we chose them – because they are very far ahead in the development of the technology of their modules, compared to other competitors.

What sorts of benefits does Huasun bring to solar projects in Switzerland?

Solar EPC projects are very dependent on the climate because of the weather and surface profile of Switzerland. We have snow and height. Obviously, we have a lot of mountains, but in the lower areas, we also have a lot of fog in the wintertime, which means you have more fluctuation in power production. So, in the last two or three years, there's been a lot of drive – including from the Swiss government – for so-called Alpine projects, which are installing PV fields above 1,500 meters, even up to 2,000 or 3,000 meters above sea level. In these areas, there's low wind and there's also no hydropower, but with solar, you can harvest electricity in January and February.

In these kinds of settings, the bifaciality of the module enables projects to generate a lot of additional electricity compared to standard modules. With Huasun HJT modules, when it becomes hot, you generate more electricity. And then, if you have an installation that is higher than 1,000 to 1,500 meters above sea level, you have the additional benefit in the summer from less damping – being even just a little bit closer to the sun makes a lot of difference on the PV module. And in the wintertime, with the snow, you get a lot of reflected light on the front and back side. [PV](#)



“In the wintertime, with the snow, you get a lot of reflected light on the front and back side”

**Markus Bäckmann,
3S**

Around the world in HJT

650 MW Apriltsi Village Solar Park

Pazardzhik, Bulgaria

Huasun Energy works as the exclusive HJT module provider for the largest HJT utility solar project in the world. The project owner reports 32% higher energy yield than expected based on initial calculations thanks to the great performance of the high-efficiency HJT modules, which delivered high energy yield.



300 MW Dali Utility Project

Yunnan, China

The large-scale solar power plants are constructed on the mountains in Dali, and the integration of Huasun high-efficiency G12-132 HJT modules will aid the prefecture in achieving its clean energy targets for the future.

50 MW Weifang Agrivoltaic Project

Shandong, China

As the largest operational agrivoltaics project using HJT technology in China, the project has become a model of win-win development for photovoltaics and agriculture. The cutting-edge Huasun Himalya G12-132 HJT modules are operating exceptionally well, contributing to higher energy yield and reduced carbon emissions.



5.2 MW Agri Solar Park

Merzig-Wellingen, Germany

The project is located in southwestern Germany on a field surface of 15 hectares. The benefits of the vertical agrivoltaics system of Next2Sun are presented by the power production in the morning and evening, in addition to the agricultural usage of the field. Due to the usage of Huasun's HJT modules, the yield is 12% higher than expected.

23 MW Xuancheng Fishery Photovoltaic Project

Anhui, China

The project is a remarkable combination of photovoltaics and a fishery. Despite the challenging and highly wet environment on the water surface, the project operates seamlessly thanks to the application of Huasun's highly reliable HJT modules.





15 MW Ningguo C&I Rooftop Project

Anhui, China

The installation of Huasun Himalaya HJT modules on the rooftops of plants and sheds has transformed the area into a green factory. This is attributed to the modules' outstanding power output, conversion efficiency, and energy yield, which make them ideal for C&I distributed solar applications with limited space.

6 MW Hamamatsu Utility Project

Shizuoka, Japan

Huasun provided its state-of-the-art heterojunction modules to its first utility solar power project in Japan.

The exceptional performance of the products ensures the project's stability and success.



43 kW Residential Rooftop Project

Thun, Switzerland

The rooftop solar project utilizes Huasun frameless HJT modules with PIB encapsulation. These modules offer exceptional self-cleaning capabilities and strong performance in low light conditions, resulting in increased energy yield and improved returns for the owner.

No.1 in Heterojunction

Capacity

20GW+

Shipment

5GW+

750.54W^[1]
24.16%

The
Highest-efficiency
HJT Module^[2]

BloombergNEF

Tier1

^[1] Certified by TÜV SÜD

^[2] Source: TaiyangNews Top Modules

Build a ZERO Carbon World



366.12g CO₂ eq/W
Lowest PV Module Carbon Emission

Certified by TÜV Rheinland in July 2023